

# Large Commercial Jet Spectrum Meters

## Product Datasheet

### Applications

The Spectrum Jet single-jet meter is the widest ranged, single measuring element meter available to U.S. utilities. The operation of the single jet element allows the meter to be applied in the vast majority of potable cold water, reclaim water and well applications. Coupled with the advanced Prism registers, the Spectrum Jet single-jets are the meter of choice for your revenue assurance and water loss programs.

The large Spectrum Jet meters come in a selection of configurations for 3-inch, 4-inch and 6-inch applications. The meter has a very wide range so there is no compromise at either low or high flows. All Spectrum Jet Model-D meters are top-loading, chamber designs which allow for field maintenance and repairs.

### Operations

Incoming water rotates a suspended impeller that is magnetically linked to the register. A low friction tungsten carbide bearing supports the impeller at low flow rates while a tungsten carbide thrust bearing provides the support at high flow rates. This unique “dual bearing” design provides unparalleled accuracy and durability at both high and low flows.

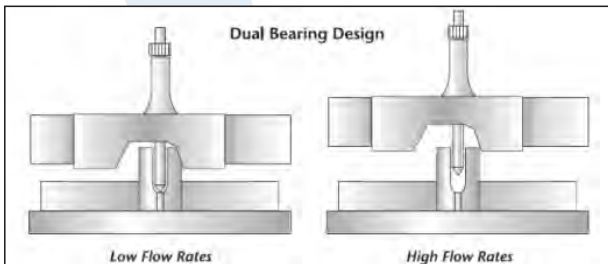

To maintain accuracy, the meter must be installed horizontally ( $\pm 10^\circ$ ) in the direction of water flow. Each of the meters come with an integral test port on the outlet flange. Although regular maintenance is not required, the Spectrum Jet Model D meters have a top-loading measurement chamber for simple access without removing the meter from service. The chamber is bolted to the meter body and secured with a tamper seal.

All Spectrum Jet Model D meters utilize Prism registers. These sealed electronic registers provide a high resolution interface to the meter and have multiple cellular, AMR, AMI and SCADA outputs. All registers are attached with a robust tamper-resistant housing.

Spectrum Jet 175D



Spectrum Jet 500D

Spectrum Jet 1000D



### Design Features

- High accuracy below AWWA standards
- Wide range—1000:1 turndown
- Superior low flow registration
- Compact and light
- Convenient options for various lengths and connections
- Low pressure drop
- No regular maintenance
- Excellent performance in adverse water conditions
- Unaffected by sand or small debris in line
- No straight pipe requirements – upstream or downstream
- No strainer requirement
- 5-year flange-to-flange warranty
- 20-year warranty on meter body
- Compatible with all Prism registers and associated AMR/AMI capabilities.

### Materials

All Spectrum Jet Model-D meters are designed and manufactured to meet or exceed AWWA C712 standard design and performance specifications. All Models are maintained with NSF-61G lead-free certifications.

### Standards

AWWA C712 – Single-Jet Meters

NSF-61G – Drinking Water System Components Health Effects

## Mechanical Specifications

### Spectrum Jet 175D - 3" (80mm)

Flanges	Lay Length	Dimensions	Weight	Z-Plate Strainer*	SS Spacer Spools	Test Port
Round 4-bolt	11.8" (300mm)	See Drawing	32lb (14.5kg)	Available (6" LL)	Hard-flanged or adjustable	Integral 1" NPT Threads

### Spectrum Jet 500D - 3" (80mm)

Flanges	Lay Length	Dimensions	Weight	Z-Plate Strainer*	SS Spacer Spools	Test Port
Round 4-bolt	13.75" (349mm)	See Drawing	41lb (18.6kg)	Available (6" LL)	Hard-flanged or adjustable	Integral 1" NPT Threads

### Spectrum Jet 500D - 4" (80mm)

Flanges	Lay Length	Dimensions	Weight	Z-Plate Strainer*	SS Spacer Spools	Test Port
Round 8-bolt	13.75" (349mm)	See Drawing	48lb (21.7kg)	Available (7.5" LL)	Hard-flanged or adjustable	Integral 1" NPT Threads

### Spectrum Jet 1000D - 4" (100mm)

Flanges	Lay Length	Dimensions	Weight	Z-Plate Strainer*	SS Spacer Spools	Test Port
Round 8-bolt	17.75" (349mm)	See Drawing	78lb (35.4kg)	Available (7.5" LL)	Hard-flanged or adjustable	Integral 1" NPT Threads

### Spectrum Jet 1000D - 6" (150mm)

Flanges	Lay Length	Dimensions	Weight	Z-Plate Strainer*	SS Spacer Spools	Test Port
Round 8-bolt	17.75" (349mm)	See Drawing	89 lb (40.4kg)	Available (8.9" LL)	Hard-flanged or adjustable	Integral 1" NPT Threads

\*Contact Metron for information on brass spools and couplers.

## Materials

Body & Top-plate	Impeller	Impeller Bearings	Impeller Shaft	Register Housing
ASTM C875 - Lead Free Bronze	Polypropylene	Tungsten Carbide	AISI 303, Tungsten Carbide Tip	Thermoplastic

## Tamper Features

Meter Body	Register
Wire + Lead Seal Between Meter Body and Top-Plate	Tamper-resistant Screw

## Markings

Engraved on Meter Body:

- Model
- Serial Number
- Date of Manufacture
- NSF-61G
- Direction of Flow

## Dimensions

Spectrum Jet 175D - 3" Model

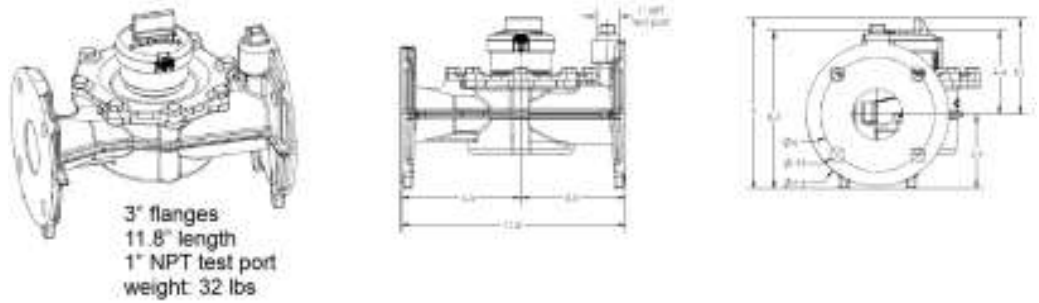

Spectrum Jet 500D - 3" Model

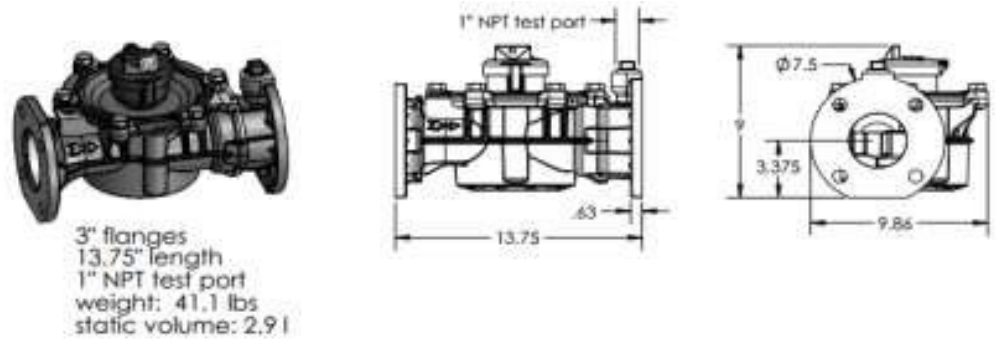

Spectrum Jet 500D - 4" Model

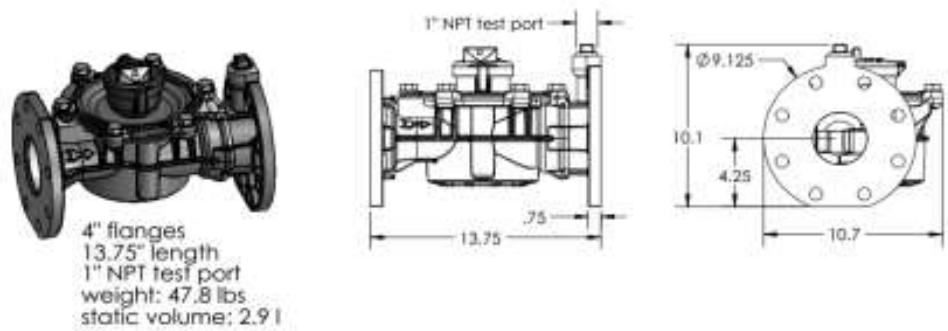

Spectrum Jet 1000D - 4" Model

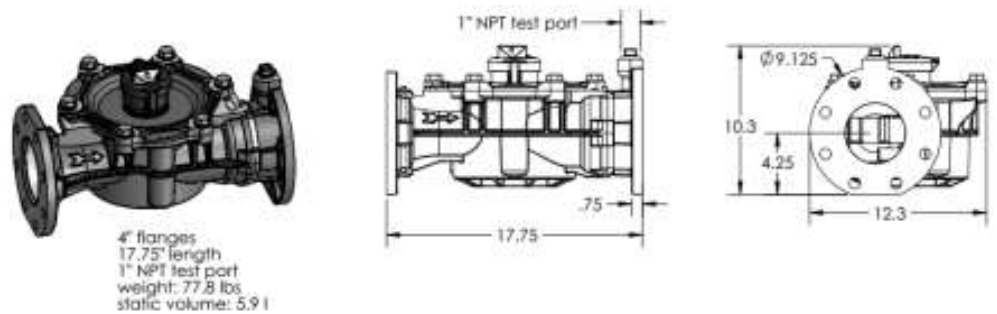

Spectrum Jet 1000D - 6" Model

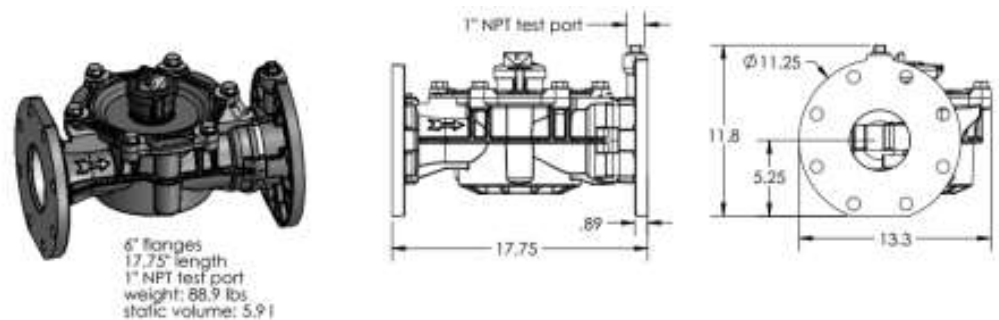

## Flow & Pressure Specifications

### Spectrum Jet 175D - 3" Models

Operating Range (98.5 to 101.5%)	0.75 to 350 gpm	0.34 to 113.5 m <sup>3</sup> /hr
Low Flow (95% min)	0.5 gpm	0.17 m <sup>3</sup> /hr
Max Continuous Flow <sup>1</sup>	175 gpm	79.5 m <sup>3</sup> /hr
Max Intermittent Flow <sup>2</sup>	245 gpm	113.5 m <sup>3</sup> /hr
Peak Test Flow <sup>3</sup>	350 gpm	136 m <sup>3</sup> /hr
Pressure Loss at Max Continuous	7.25 psi	0.5 bar
Max Operating Pressure	230 psi	15.9 bar
Max Operating Temperature	120° F	48.9° C

### Spectrum Jet 500D - 3" and 4" Models

Operating Range (98.5 to 101.5%)	1.5 to 500 gpm	0.34 to 113.5 m <sup>3</sup> /hr
Low Flow (95% min)	0.75 gpm	0.17 m <sup>3</sup> /hr
Max Continuous Flow <sup>1</sup>	350 gpm	79.5 m <sup>3</sup> /hr
Max Intermittent Flow <sup>2</sup>	500 gpm	113.5 m <sup>3</sup> /hr
Peak Test Flow <sup>3</sup>	600 gpm	136 m <sup>3</sup> /hr
Pressure Loss at Max Continuous	7.25 psi	0.5 bar
Max Operating Pressure	230 psi	15.9 bar
Max Operating Temperature	120° F	48.9° C

### Spectrum Jet 1000D - 4" and 6" Models

Operating Range (98.5 to 101.5%)	2.0 to 1000 gpm	0.34 to 113.5 m <sup>3</sup> /hr
Low Flow (95% min)	1.0 gpm	0.17 m <sup>3</sup> /hr
Max Continuous Flow <sup>1</sup>	600 gpm	79.5 m <sup>3</sup> /hr
Max Intermittent Flow <sup>2</sup>	1000 gpm	113.5 m <sup>3</sup> /hr
Peak Test Flow <sup>3</sup>	1100 gpm	136 m <sup>3</sup> /hr
Pressure Loss at Max Continuous	7.25 psi	0.5 bar
Max Operating Pressure	230 psi	15.9 bar
Max Operating Temperature	120° F	48.9° C

#### Notes:

1. Max Continuous defined by AWWA as flow rate which can be maintained 24 hrs/day x 7 days/week
2. Max Intermittent defined as flow rate which can be maintained 1 hr/day average
3. Peak Test flow defined as absolute max flow rate which can be maintained for brief periods under stable conditions while maintaining a minimum of 20 psi downstream of the meter.

## Flow & Pressure Specifications

### Spectrum Jet 175D

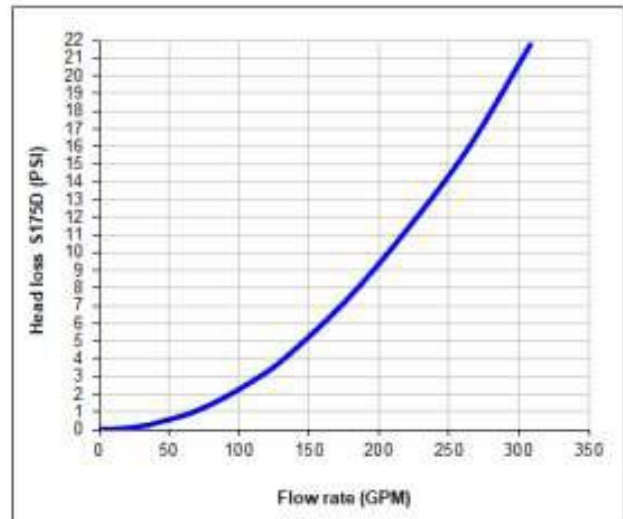
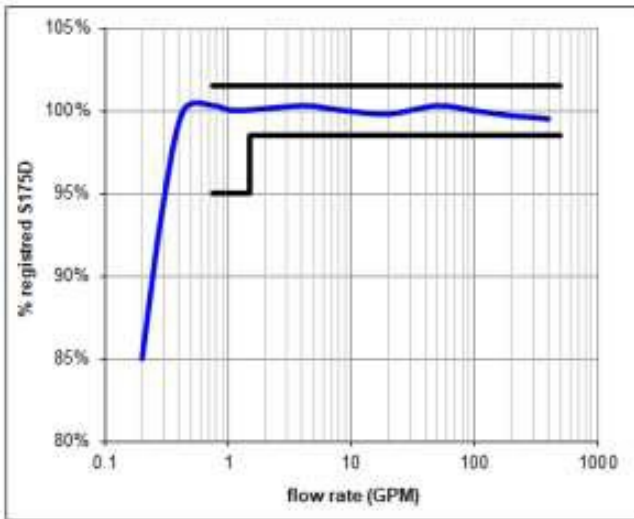

### Spectrum Jet 500D

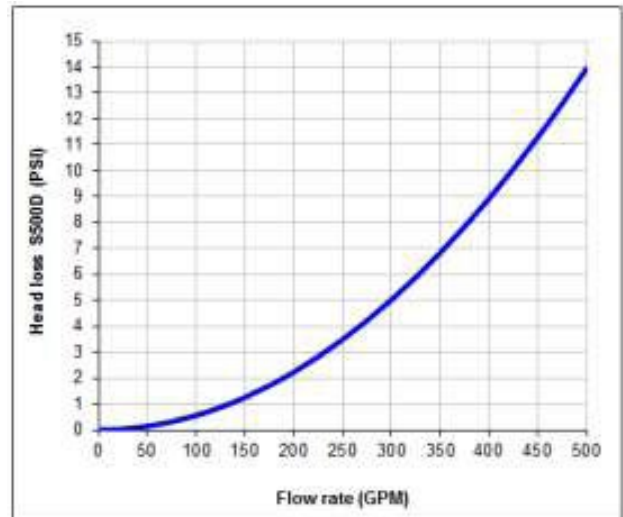
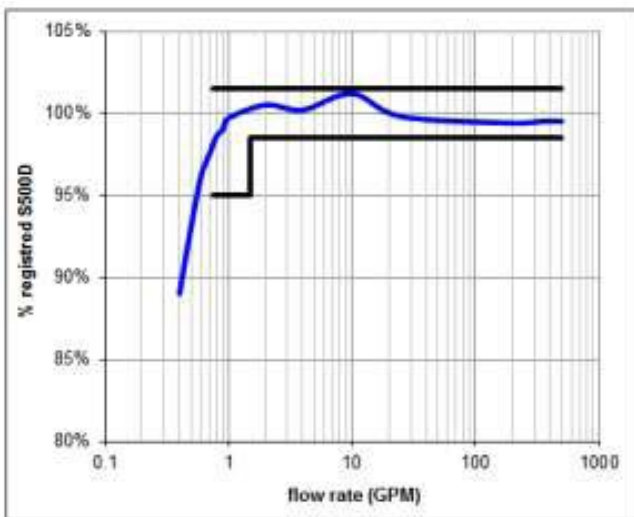

### Spectrum Jet 1000D

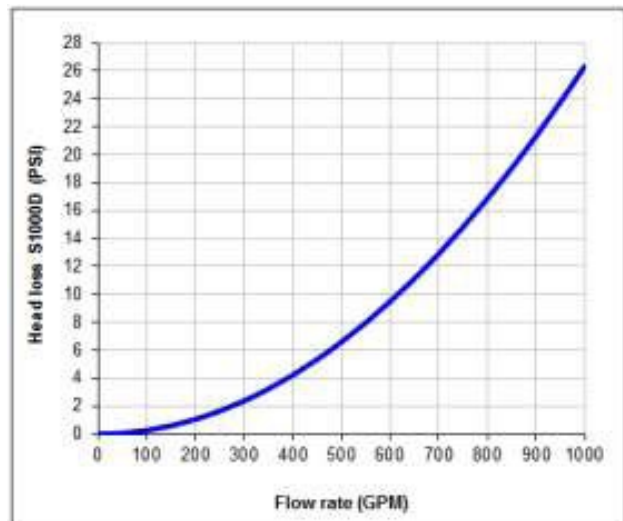
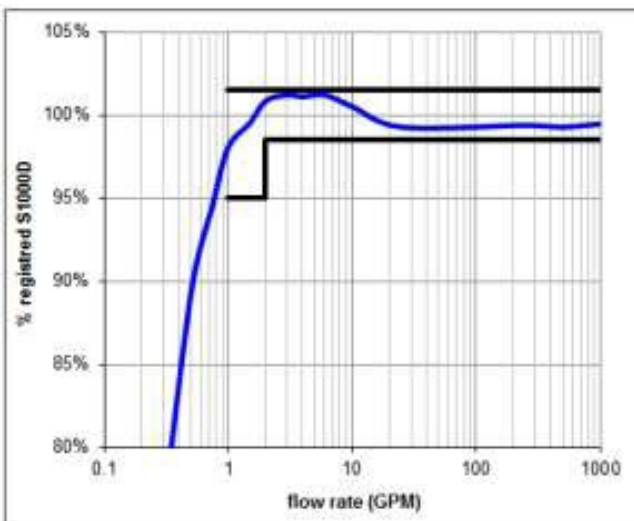



## Registers

The Prism electronic register is the water industry's new standard for register performance. The Prism offers maximum resolution, a multitude of standard features, on-board datalogging and a variety of cellular, AMI, AMR and SCADA output options. The Prism is designed for all environments and incorporates the largest battery available for utility applications. The Prism can be deployed on any Metron Spectrum Jet water meter.

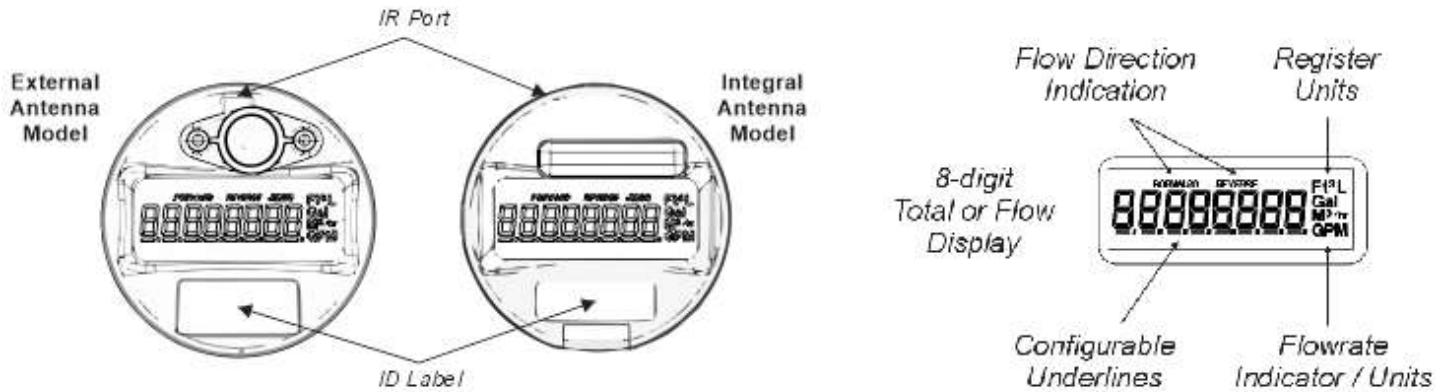

**USG Configuration**  
1 Gallon Resolution



**Ft3 Configuration**  
0.1 Ft<sup>3</sup> Resolution

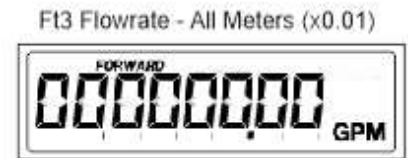

**m3 Configuration**  
0.01 m<sup>3</sup> Resolution



## Warranty

Please contact your Metron representative for formal warranty certificates.

## Legal

Due to updated regulations and product improvements, Metron-Farnier reserves the right to change the product specifications without notice.