



# METRON Spectrum HYDRANT

## Spectrum Hydrant

### Hydrant meter with daily cellular reading

The Spectrum Hydrant meter provides a flow range suitable for measuring hydrants and other construction service applications. The lightweight, top-loading meter can be fitted for any utility or construction requirements. Combined with a Prism cellular digital register, it uploads water usage data to the cloud, where it can be viewed and analyzed using Metron's WaterScope® platform.

### Benefits

- Cellular connection via Verizon Wireless™ network - no special infrastructure needed.
- Web-based reading and billing updated daily, accessed in WaterScope® on the web or in an app.
- No more off-route or "traveling meter" manual readings.
- No monthly or annual cellular charges.
- No waiting for contractor call-ins.

### Optional GPS Tracking

Never lose a meter again! The optional GPS tracker collects location coordinates 16x per day. You can view the meter's location history in WaterScope. The GPS tracker's field battery lasts 3+ years.



## Spectrum Hydrant features

- Calibratable measuring chamber
- Field-replacable measuring chamber
- Protective register cage
- Lightweight epoxy-coated aluminum body
- For horizontal or vertical installation
- Outstanding long-term accuracy through hydraulic bearing relief
- Compatible with Prism electronic register
- Warranty: 5-year - materials and workmanship

## Physical Specifications

- Type: Turbine
- Body: Epoxy-coated aluminum
- Register: Prism
- Dimensions: See figure 1
- Weight: 17 lbs (with fittings)

## Functional Specifications

- Fluids measured: Potable cold or reclaimed water
- Flow range: see table 1
- Accuracy:  $\pm 1.5\%$ , for flow range 2-600 GPM
- Pressure loss: 6 PSI @ 500 GPM
- Max operating temperature: 140°F (60°C)
- Nominal pressure: 232 PSI (16 bar)
- Standard: AWWA C701 Class II

Figure 1: Spectrum Hydrant meter dimensions

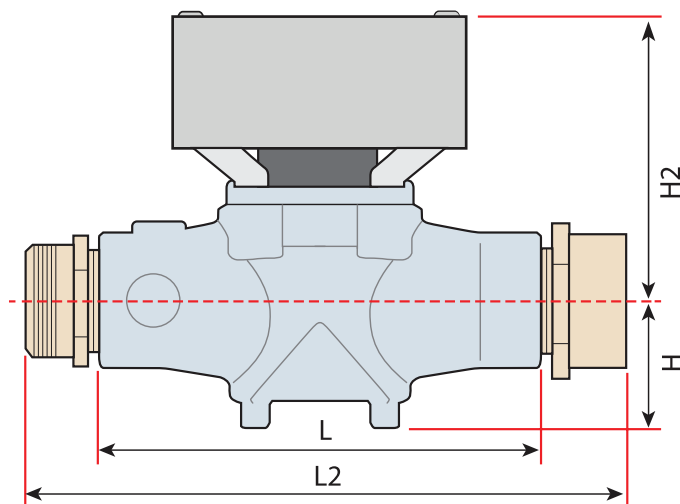

Nominal Thread Diameter		2.5	in.
Overall Length (no couplings)	L	11.8	in.
Overall Length (w/couplings)	L2	15.7	in.
Overall Height		13	in.
Bottom-Centerline Height	H	3.37	in.
Top-Centerline Height	H2	5.5	in.
Width		6.7	in.
Weight		17	lbs

Table 1: Flow specifications and curves

Model	Size	Minimum Flowrate <sup>1</sup> (95% - 101.5%)	Normal Operating Range (98.5% - 101.5%)	Maximum Continuous Duty <sup>2</sup>	Max Intermittent Flow <sup>3</sup>	Head Loss & Max Continuous Flow
Voyager	3"	2.0 <i>gpm</i>	3.5 500 <i>gpm</i>	500 <i>gpm</i>	800 <i>gpm</i>	6.0 <i>psi</i>

All flow specifications assume typical, consistent system pressure conditions. Adverse pressure conditions will affect the performance of the meters.

1 Minimum Flowrate: This flow is applicable for both horizontal and vertical alignment.

2 Max Continuous flow: Defined as the flow rate which can be maintained 24 hrs/day for 7 days/week.

3 Max Intermittent flow: Defined as the flow rate which can be sustained for approx. 1 hour per day average.

Learn more on our website: [metron-us.com](https://metron-us.com)

Call 303.449.8833 to speak to a member of our sales team, or email us at: [hello@metronfarnier.com](mailto:hello@metronfarnier.com)

